

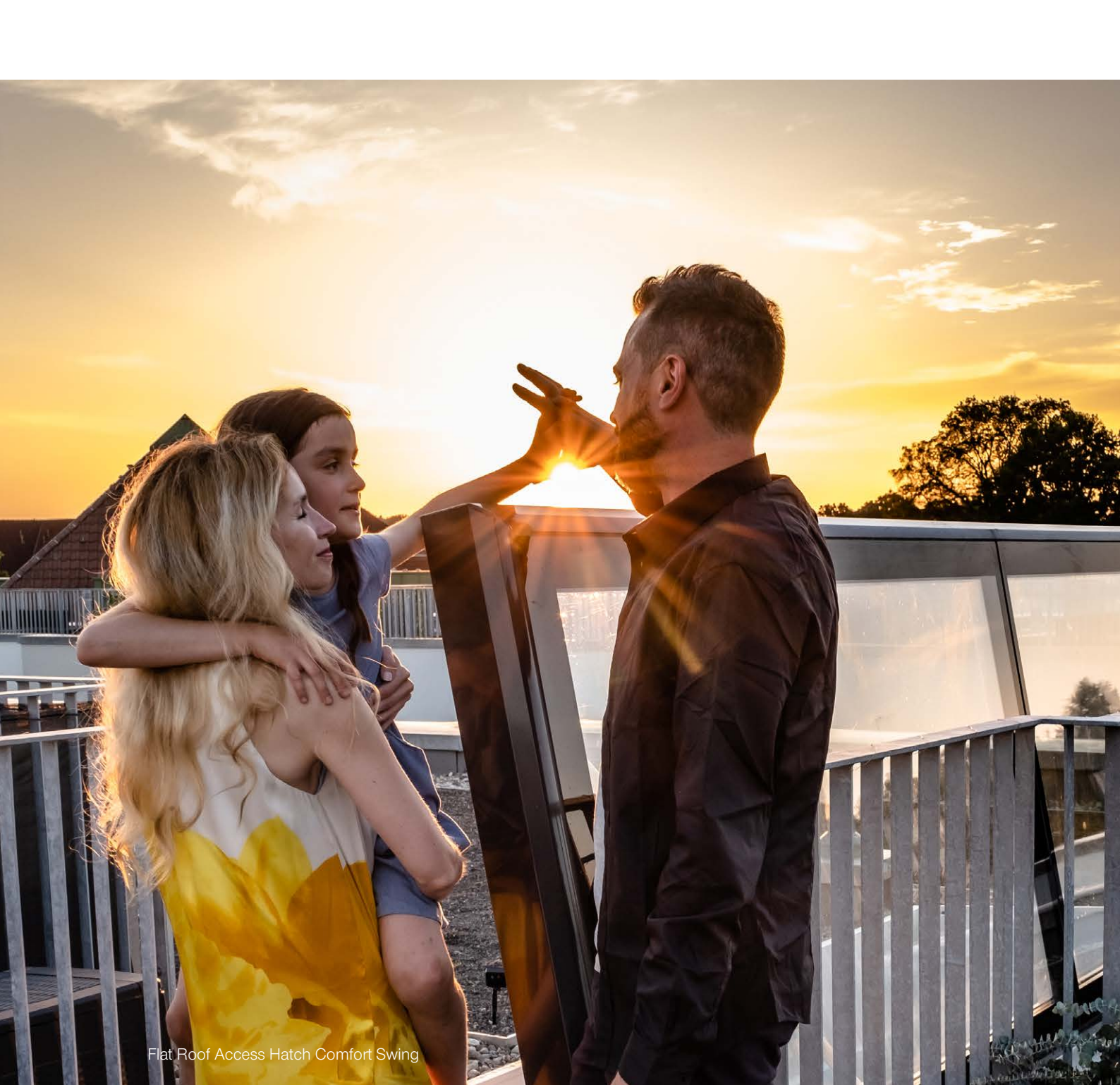

**LAMILUX FLAT ROOF ACCESS HATCH COMFORT  
LIGHT SOURCE WITH AN EXCLUSIVE DESIGN**



Flat Roof Access Hatch Comfort Swing



### The LAMILUX CI Philosophy

Customer value is the reason we exist – and the focus of our activities. This requires harmony, identity and a balance between customer value and company strategy.

The principles that guide our company's actions and customer relations are set out in LAMILUX's company philosophy:

#### **Customised Intelligence – serving customers is our first priority:**

This requires outstanding performance and leadership in all areas relevant to customers, particularly in the role of:

- A leader in quality – optimum benefit for customers
- A leader in innovation – at the cutting edge of technology
- A leader in service – fast, uncomplicated, reliable and friendly
- A leader in expertise – optimum advisory services
- A leader in solving problems – individual, tailor-made solutions

# LAMILUX FLAT ROOF ACCESS HATCH COMFORT

**In the past, flat roof access hatches were used purely as roof access for maintenance and inspection purposes. In the meantime, other aspects of use have been added and the demands on the skylights have become much more complex. In addition to optimised thermal insulation values and proven durability, the focus is primarily on architectural standards and comfort.**

For exclusive top floor apartments, this achieves unprecedented daylight incidence and creates a comfortable opportunity for roof access. The indoor environment also benefits from the systems' high energy efficiency and their unrestricted use as a ventilation system.



## The highest quality standards

For us, quality does not only mean high energy efficiency for our products, but also durability through the use of the highest quality materials, certified functional safety for daily use, and perfectly shaped design.

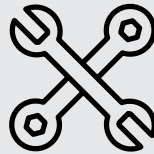

## Delivered pre-assembled to the construction site

We deliver all our elements completely pre-assembled to the construction site. Only the control unit needs to be installed on site for the Flat Roof Access Hatch Comfort Solo. This reduces the amount of crane work, fasteners, and seals.

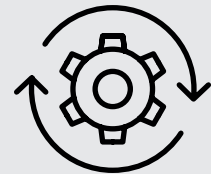

## Proven functionality

As a planner and installer, you benefit from the simple and fast usability of our flat roof access hatches, which brings security with regard to weather, whilst saving time and costs, as once the roof is closed, dry construction can begin.



Flat Roof Access Hatch Comfort Square



Flat Roof Access Hatch Comfort Swing



Flat Roof Access Hatch Comfort Solo



### Energy efficiency

- Savings on heating costs and minimised risk of condensation thanks to flawless isothermal characteristics
- All-round optimum thermal insulation in a compact overall system free of thermal bridges
- Retention of ample heat energy in the building due to the frame construction
- Optionally equipped with functional glazing of superior quality (on request)



### Comfort and design

- Easy processing thanks to completely pre-assembled delivery of the Flat Roof Access Hatch
- Self cleaning – due to level water drainage\* and inclined upstand
- Concealed drives offer a particularly high quality interior
- Stepless ventilation with pushbutton function

## ALL BENEFITS AT A GLANCE

---



### Safety

- Roof access hatch provides fall-through protection in closed position as per DIN EN 18008-6
- Entry and exit area monitored by light barrier or motion detector
- Meets the requirements of the Machinery Directive



### LAMILUX product configurator

- Create individual product variant, guided by a dynamic dialogue with 3D preview in real time
- Share, request or download BIM objects, 2D and 3D CAD models, images, dimensional drawings and Data sheets in your desired file format with just one click
- Support for your individual glass roof or continuous rooflight project



[lamilux.com/bim](https://lamilux.com/bim)



Flat Roof Access Hatch Comfort Swing

## FLAT DRAINAGE SURFACE\*

The unique frame profile provides a smooth transition between the glazing and the border frame, creating a flat drainage surface. The flat glass surfaces are connected to the support system of our LAMILUX Flat Roof Exit Hatch Comfort Swing and Square units without visible fixings.

In combination with the inclined upstand, our systems offer optimal water drainage from the pane. The clever anchoring of the glazing in the system avoids troublesome dirty edges. The rainwater run-off rinses dust and small impurities from the glass pane. Daylight enters the living space unhindered and ensures a continuous feel-good atmosphere.

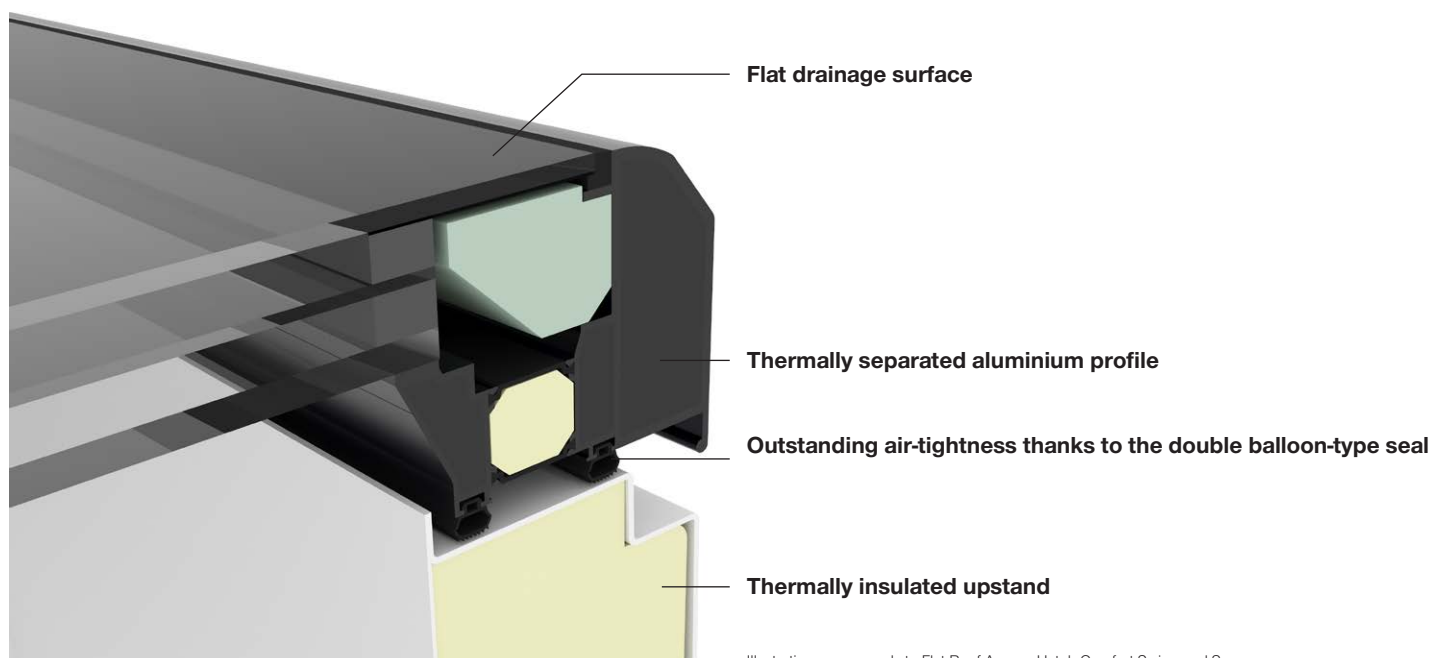

Illustration corresponds to Flat Roof Access Hatch Comfort Swing and Square

# LAMILUX FLAT ROOF ACCESS HATCH COMFORT SWING

The LAMILUX Flat Roof Access Hatch Comfort Swing was awarded the German Design Award 2020 in the category "Special Mention" and is the winner of the "haustec.de Readers' Choice 2021". It enables a high level of daylight incidence for exclusive penthouse flats in an aesthetically and architecturally appealing implementation. Thanks to its ingenious folding technology, the flat roof exit hatch offers even more convenient access to the roof.

The Flat Roof Access Hatch Comfort Swing is available in two versions. We offer a 300 and 350 cm long version. The system is opened by means of electrically controlled hydraulic cylinders. Mechanics and controls are concealed in the system and ensure an attractive and clean design. The access hatch folds up like a horizontal door to grant access to the path to the roof, which is roughly 100 cm wide. The element needs only about 25 seconds to reach its maximum opening angle of 84 degrees. Due to the compact design and the opening mechanism, valuable roof space can be used elsewhere. The five-degree inclined upstand supports water drainage from the pane.

## Top roof edge sizes in cm

width	length
100	300
100	350

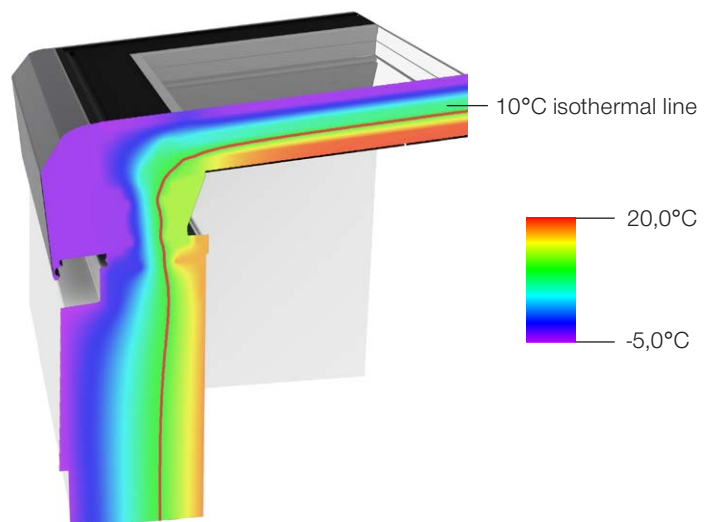





# LAMILUX FLAT ROOF ACCESS HATCH COMFORT SQUARE

The LAMILUX Flat Roof Access Hatch Comfort Square has already been awarded the Red Dot Design Award 2021 in the category "Product Design". It offers the best fit for the roof terrace and creates architectural freedom. The square shape means that spiral or platform staircases can be used, which meets purist design requirements in particular.

Thanks to a filigree frame construction with a light area of 4 m<sup>2</sup>, the Flat Roof Access Hatch Comfort Square offers maximum daylight incidence. The concealed hydraulic drives ensure a clean design. The element needs only about 45 seconds to reach its maximum opening angle of 70 degrees. This offers a high level of comfort, saves space on the roof terrace and ensures sufficient fresh air inside the building. The five-degree inclined upstand supports water drainage from the pane.

Top roof edge sizes in cm

width	length
200	200

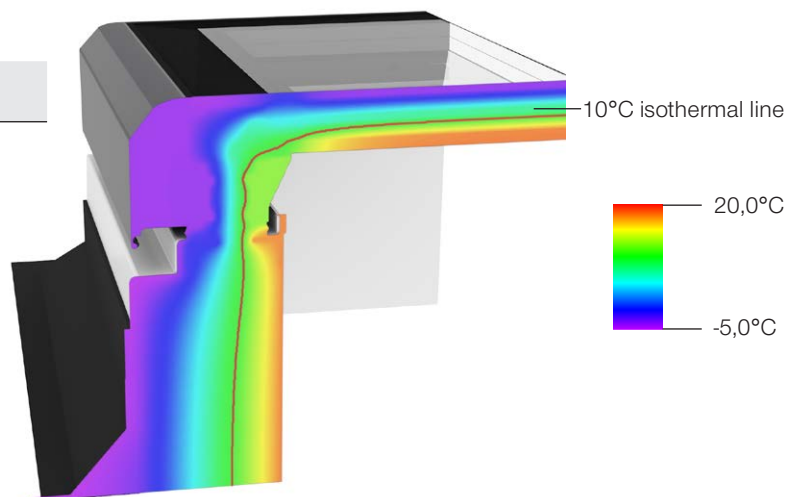



red dot winner 2021

# LAMILUX FLAT ROOF ACCESS HATCH COMFORT SOLO

The LAMILUX Flat Roof Access Hatch Comfort Solo was awarded the German Design Award 2017 in the category "Special Mention". Thanks to its filigree frame construction, it offers maximum daylight incidence. The 6° inclined glass surface and a flat water drainage system create an optimised self-cleaning effect.

The Flat Roof Access Hatch Comfort Solo moves its upper part horizontally and steplessly on support rails by means of concealed electric motor openers. The concealed and weather-protected design of the motors ensures a clean interior with a maximum opening area of 109 x 318 cm.

Top roof edge sizes in cm

width	length
120	350

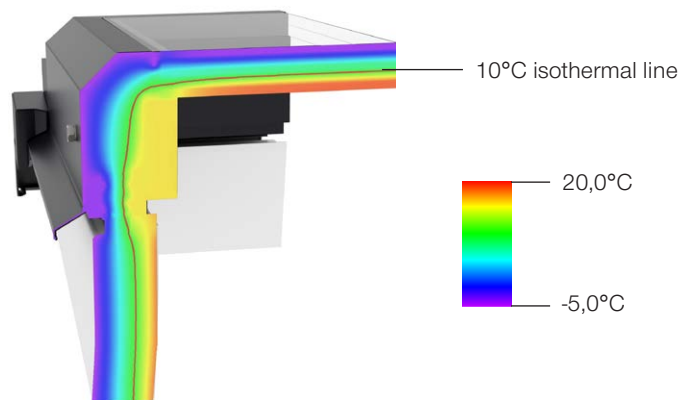





# LAMILUX FLAT ROOF ACCESS HATCHES COMFORT REFERENCES

---

## LAMILUX FLAT ROOF ACCESS HATCH COMFORT SWING

### Townhouse - Hohen Neuendorf

The large amount of daylight, controllable ventilation and comfortable access to the roof terrace have created a luxurious living space for the most discerning tastes.

The opening is infinitely variable over the entire top-hung flap with hinges on the long side. The maximum opening angle is approx. 84°.



## FLAT ROOF ACCESS HATCH COMFORT SWING

### **Residential house – Denmark**

The Flat Roof Access Hatch Comfort Swing made it possible to create a space-saving access to the roof terrace and thus an exclusive ambience.

The Comfort Swing can be opened steplessly over the entire area like a door. It has a compact, highly energy-efficient overall construction, which rests on a fully insulated upstand made of glass-fibre reinforced plastic with an integrated core insulation block.



## FLAT ROOF ACCESS HATCH COMFORT SOLO

### Residential house, Paris – France

Thanks to the Flat Roof Access Hatch Comfort Solo, a noble ambience with a view over the roofs of Paris could be realised. This is combined with a pleasant incidence of light for the attic flats.

The overall system, which is free of thermal bridges, optimised isothermal processes and the option of special glazing also meet modern demands for sustainability, energy efficiency and climate protection.





## FLAT ROOF ACCESS HATCH COMFORT SOLO

### Residential house – Berlin

Due to local regulations, access via a stairwell was not possible. However, thanks to the Flat Roof Access Hatch Comfort Solo, this could be resolved.

A stepless opening of the flap enables a roof access hatch that can also be used as a ventilation option. Control is via an external 24V rack drive on stainless steel telescopic rails with brush seal.

# ACCESSORIES

## RAL OF YOUR CHOICE

**Design not only the glazing, but also the colour of the Flat Roof Access Hatches freely according to your imagination.**

The aluminium profiles can be coloured both outside and inside according to individual taste (RAL of choice). Whether black and white, blue and red or other combinations, we design the flat roof access hatch according to your requirements.

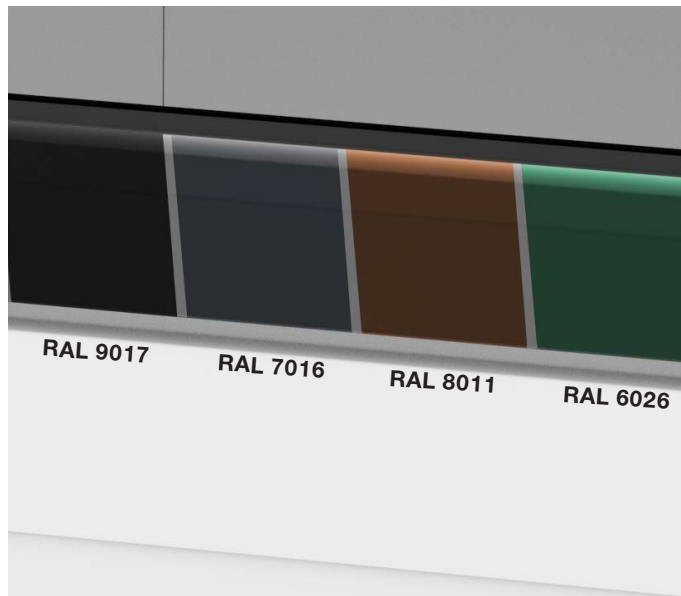

## ALARM LOOP\*

**It doesn't get any safer than that. The demand for safety in property and personal protection is constantly increasing. In addition to burglar-resistant glass, alarm glass that has an "alarm loop" already integrated into the glass can provide greater safety.**

The alarm loop is incorporated into the corner of the external toughened safety glazing. This protects it from the weather. If an attempt is made to break in through the flat roof access hatch and the glass breaks, an electrical conductor loop is interrupted, which is connected to an alarm system. This triggers an intruder alarm system.

\* Available for Flat Roof Access Hatch Comfort Swing and Square

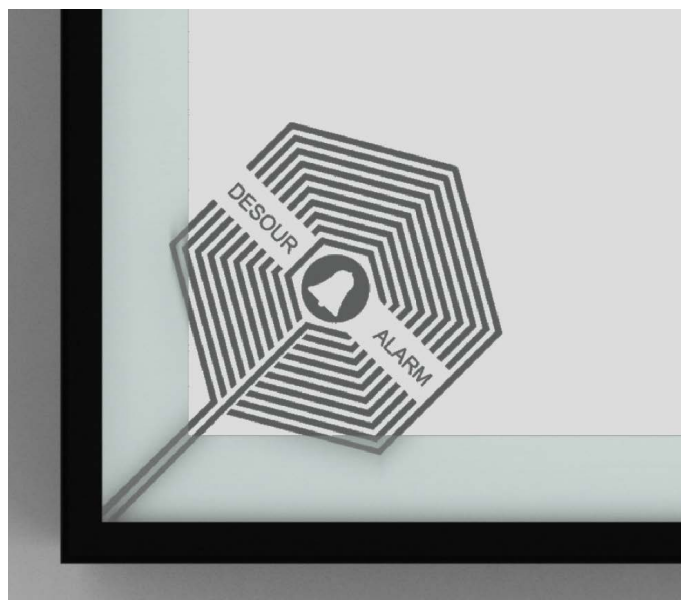

## SUN PROTECTION\*\*

**Daylight intake and solar heat input create great potential for channelling energy into buildings and making savings on costs for heating and artificial light. This should not be achieved in an uncontrolled way, but must be regulated and guided by controllable shade systems.**

The external shade system for our LAMILUX Flat Roof Access Hatches is suitable for this. With noise-optimised retraction sliders, the external blind can be easily extended by a pushbutton switch or radio remote control and thus optimally control the incidence of daylight. The cable routing is concealed in the upstand element. The blind is approved up to wind resistance class 4 according to DIN 13561 (38-48 km/h).

\*\* Available for Flat Roof Access Hatch Comfort Solo, Swing and Square



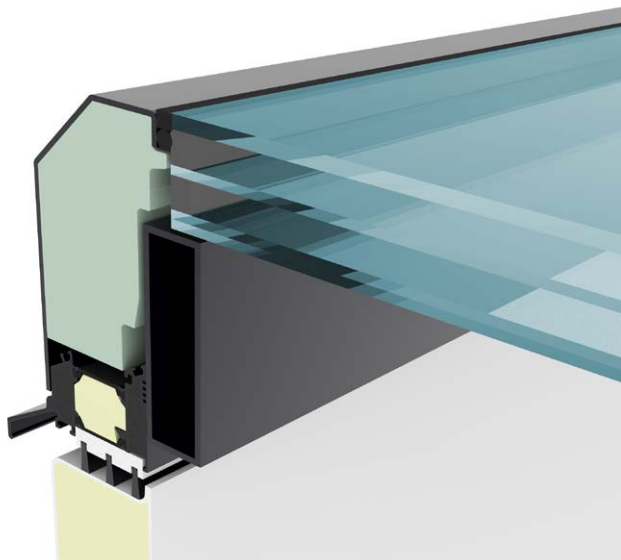

## GLAZING

**We offer a wide range of functional glass for the glazing of flat roof access hatches.**

In addition to the standard thermal insulation glazing, various solar protection glazing variants and Bio Clean glazing are available. You have the choice between clear and opal design. Customised glazing variants are available on request.

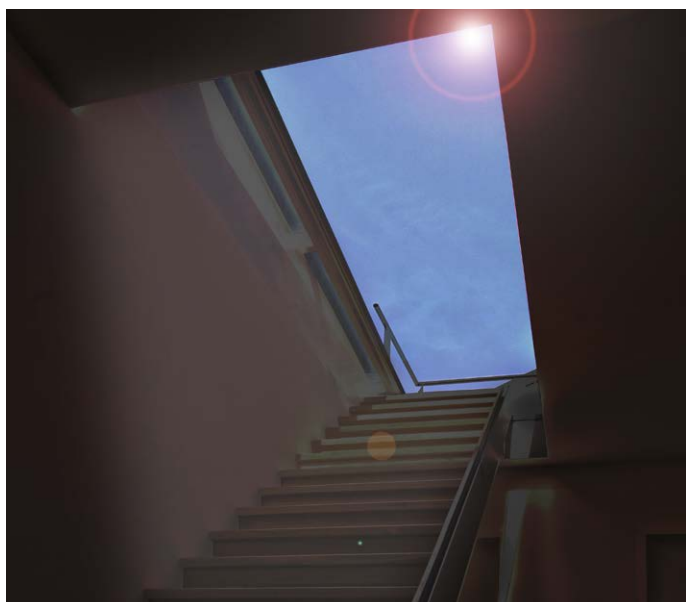

## EMERGENCY POWER SUPPLY FOR SECOND ESCAPE ROUTE\*\*\*

**The LAMILUX Flat Roof Access Hatches offer multiple functionality. Not only are they suitable for regular natural air exchange, the roof access hatches can optionally be buffered with emergency power supply via 24V battery for a second escape route.**

A second escape route is required, for example, if rescue is not possible via a safely accessible stairwell into which fire and smoke cannot penetrate. Our flat roof access hatches can optionally be designed as a second escape route with emergency power buffering and can be used for this purpose in accordance with local regulations.

\*\*\* is always to be confirmed or checked and approved by the authorities, municipal and in the district, no SHEV



## BIM – PRODUCT CONFIGURATOR

**Configure customised product variants with Building Information Modelling (BIM), guided by a dynamic dialogue with 3D preview in real time.**

Share, request or download BIM objects, 2D and 3D CAD models, images, dimensional drawings and data sheets in your desired file format with just one click. We are also happy to support you with your individual glass roof or continuous rooflight project. Our experienced BIM experts develop a customised BIM model according to your requirements and export the BIM project for your software environment. Simply send us your project via the contact form and we will start planning together.



Scan this to learn more about  
LAMILUX skylights!

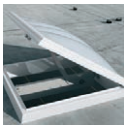

ROOFLIGHT F100 W



GLASS SKYLIGHT F100



GLASS SKYLIGHT FE



GLASS ARCHITECTURE



RENOVATION



MIROTEC STEEL CONSTRUCTIONS



CONTINUOUS ROOFLIGHT B/S



FLAT ROOF HATCHES



MODULAR GLASS SKYLIGHT MS 78



SMOKE AND HEAT EXHAUST  
VENTILATION SYSTEMS



BUILDING SMOKE EXTRACTION



RODA LIGHT AND AIR TECHNOLOGY

The technical data listed in this brochure correspond to the current status at the time of printing and are subject to change. Our technical specifications are based on calculations and supplier specifications, or have been determined by independent testing authorities within the scope of applicable standards. Thermal transmission coefficients for our plastic glazing were calculated using the finite element method with reference values in accordance with DIN EN 673 for insulated glass. Taking into account practical experience and the specific characteristics of plastic, the temperature difference between the outer surfaces of the material was defined as 15 K. Functional values refer to test specimens and the dimensions used in testing only. We cannot provide any further guarantees of technical values. This particularly applies to changed installation conditions or if dimensions are re-measured on site.



**LAMILUX Heinrich Strunz GmbH**

Zehstraße 2 . PO Box 1540 . 95111 Rehau . Tel.: +49 (0) 92 83 / 5 95-0 . Fax +49 (0) 92 83 / 5 95-29 0

E-Mail: [information@lamilux.de](mailto:information@lamilux.de) . [www.lamilux.com](http://www.lamilux.com)

